

# CANABIA



## CANABIA

*The largest Czech hemp processing  
company*

*Ing. Jaroslav Skoumal  
General managing director*



# CANABIA

- *Founded in 1996 under name AV Kontakt*
- *Engaged in hemp since 2002*
- *Based in Hodonin*
- *19 employees*
- *2006 a new factory building + warehouse*
- *Own home designed harvesting technology*



## **PRODUCTION OF HEMP HARVESTING MACHINES**

- *Participation in development and sales of unique hemp harvesting machinery*
- *Cutter bars*
- *Contrarouting cutter bars*
- *Specially adjusted square baler*



## CUTTER BAR: Type SCHUM 4.2 HH

- *Number of cutter bars:* 2
- *Width:* 4,0m
- *Drive:* hydraulic
- *Maximum working output:* 6 ha/hour
- *Distance between the bars:* 800mm
- *Transportation:* on trailer



## CUTTER BAR: Type CLIPPER 4.3 MMH

- *Number of cutter bars:* 3
- *Width:* 4,0m
- *Drive:* mechanical - hydraulic
- *Maximum working output:* 6 ha/hour
- *Distance between the bars:* 1000mm
- *Transportation:* cutter bar tilt in the transport position

- Working position

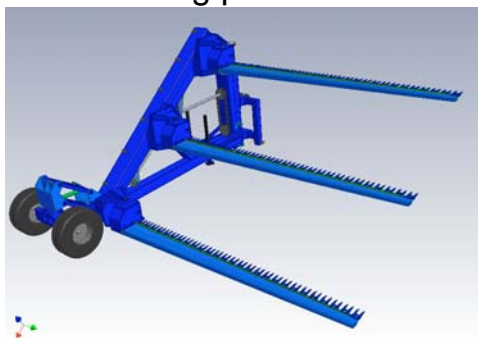

- Transport position



# BALER : Type New Holland K01 for square bales



- *Size of bale:* 2,5mx0,8mx1,2m
- *Weight of bale (10% dampness):* 550 kg
- *Drive:* mechanical
- *Maximum working output:* 4 ha/hour

## THE HEMP PRODUCTION LINE

*A pure Czech product based on proved technologies*

- *Mechanical separation of fibre and shives*
- *Maximum working output - 1.500 – 2.000 kg hemp straw / hour*
- *Input material-dew-retted straw pressed into round or square bales*
- *Lenght of hewed straw 0,8-1,0m, dampness 13 – 18 %*
- *The cleanness of the fibre – 3-25 %*
- *The fibre yield - 22-25%*
- *The electric input - 85 kW + 15-20 kW for air-con*



## THE PELLET MANUFACTURING LINE



- *Processing of the shives into pellets in diameters 6 - 20 mm.*
- *Skeleton = a grinder + 2 granulators*
- *Capacity - cca 1.5 t/hour*
- *Partially packed or sold in bulk*

## CROPS

- *CANABIA – Czech's largest producer of hemp products*
- *Varieties Beniko, Bialobrzieske, Ferimon*
- *Cultivation areas in 2006 – cca 900 ha*
- *Cca 6.000 t hemp straw = 1.500 t fibers + 4.500 t shives*
- *120 t seeds*



# PRODUCTS

- *Fibre - paper mills + textile factories*
- *Shives - fuel for power plants*
  - *animal bedding*
  - *pellets and briquettes*
- *Pellets - specific weight cca 700 kg/m<sup>3</sup>, ash content <5%*
  - *fuel efficiency cca 17 GJ/t, long incandescence period*
  - *fuel, animal bedding*



## FUTURE PLANS

- *Multiplying of cultivation areas*
- *Extending the processing technique*
- *New hemp products*



CANABIA



**CANABIA**

***THANK YOU FOR YOUR ATTENTION***

